

ICC-ES Evaluation Report

ESR-4647

Issued June 2023

This report also contains:

- FBC Supplement

Subject to renewal June 2024

- LABC Supplement

ICC-ES Evaluation Reports are not to be construed as representing aesthetics or any other attributes not specifically addressed, nor are they to be construed as an endorsement of the subject of the report or a recommendation for its use. There is no warranty by ICC Evaluation Service, LLC, express or implied, as to any finding or other matter in this report, or as to any product covered by the report.

Copyright © 2023 ICC Evaluation Service, LLC. All rights reserved.

<p>DIVISION: 05 00 00—METALS</p> <p>Section: 05 05 23—Metal Fastenings</p>	<p>REPORT HOLDER:</p> <p>HILTI, INC.</p>	<p>EVALUATION SUBJECT:</p> <p>F-BT STUDS INSTALLED WITH THE CORDLESS STUD FUSION SYSTEM</p>	
--	--	---	---

1.0 EVALUATION SCOPE

Compliance with the following codes:

- 2021, 2018 and 2015 [International Building Code® \(IBC\)](#)
- 2021, 2018 and 2015 [International Residential Code® \(IRC\)](#)

For evaluation for compliance with codes adopted by [Los Angeles Department of Building and Safety \(LADBS\)](#), see [ESR-4647 LABC and LARC Supplement](#).

Property evaluated:

Structural

2.0 USES

The Hilti Cordless Stud Fusion (CSF) System is used to weld proprietary threaded studs to carbon steel base material to facilitate the attachment of nonstructural components (components that are not part of the primary load-bearing or lateral-force-resisting systems of the structure) . The threaded studs may be used in structures regulated under the IRC, when an engineered design is performed in accordance with IRC Section R301.1.3.

3.0 DESCRIPTION

3.1 Hilti F-BT Studs and CSF System:

The Hilti F-BT studs are proprietary studs welded to steel base material using Hilti CSF equipment. F-BT studs are available with sealing washers and flange nuts supplied by Hilti (stud designations F-BT-MR SN) or without any accessories (stud designations F-BT-MR). See Figure 5 for an image of an installed F-BT-MR SN stud.

3.1.1 F-BT Studs: The F-BT studs have a fastening thread and a proprietary shape which allows for engagement with the welding tool and with the sealing washer, when applicable. See Figure 1 for general terminology for stud features. See Figure 2A for a dimension key for F-BT-MR SN studs and Figure 2B for a dimension key for F-BT-MR studs. Available stud sizes and dimensions are shown in Tables 1A and 1B. The fastening threads are available in standard metric or imperial sizes for threaded bolts. The studs are formed from 316Ti stainless steel (1.4571 X6CrNiMoTi17-12-2) material complying with the manufacturer’s specifications, with a minimum finished product tensile strength of 87.1 ksi (600 MPa). A tool weld code (H-code) for installation is embossed on the top of the stud, as shown in Figure 3.

3.1.2 Sealing Washer: The sealing washer consists of a chloroprene washer bonded to a stainless steel shell. The washer has an outside diameter of 1.38 inches (35.1 mm) for the F-BT-MR M12 SN studs and an outside diameter of 1.24 inches (31.5 mm) for all other F-BT-MR SN studs. The maximum installed height of the washer is 0.236 inch (6 mm).

3.1.3 Hilti CSF System: Tools and equipment used to prepare the surface of the supporting steel and to weld the stud to the steel include the following:

1. Hilti cordless drill driver SF 6H-22 or SF 8M-A22. This tool is used with Hilti surfacing tool FX 3-ST d14 or FX 3-ST d20, as applicable, to remove coating materials, scale, rust or other dirt from the supporting steel surface.

2. Hilti CSF unit FX 3-A. This is a battery powered, computer-controlled unit with pre-programmed weld parameters tailored to F-BT stud products. The unit controls welding variables and provides feedback to users regarding installation success. The FX 3-A sends the electrical charge for the arc welding to the stud fusion hand tool.
3. Hilti stud fusion hand tool FX 3-HT. This tool is connected to the FX 3-A unit and is used to hold the stud in position and to trigger the automated welding process.
4. Gas can FX 3-GC. This is loaded into the FX 3-A unit and supplies the arc shield gas to the hand tool.

See Figure 6 for images and more detailed information for this equipment.

3.2 Requirements for Supporting Steel:

Supporting steel material, which the stud is welded to, must be carbon steel complying with ASTM A36 or A572 Grade 50 or equivalent, with a carbon equivalent value (CEV) $\leq 0.45\%$ determined in accordance with the International Institute of Welding (IIW) formula. The minimum supporting steel thickness qualified for each stud product is shown in Tables 2A and 2B. The bare steel thickness must not exceed $1\frac{3}{16}$ inch (30 mm). The supporting steel may be bare (uncoated) or may be coated with zinc, paint or other protective coating material up to a thickness of 39 mils (1 mm).

4.0 DESIGN AND INSTALLATION

4.1 Design:

4.1.1 Available Strengths: The available shear and tension strengths for the connection of the stud to the base material are shown in Tables 2A and 2B for F-BT-MR SN and F-BT-MR studs, respectively. The associated installation parameters are also provided in Tables 2A and 2B. These are based on the Hilti Welding Procedure Specification (WPS) which accompanies this report. A sample template for documenting stud installation procedures and results of field testing for the CSF system also accompanies this report.

Limit states such as pull-over and bearing, which are governed by the properties of the attached material, are outside the scope of this report. Design of the connection of the attached material to the base material, taking into account the properties of the attached material, must comply with the applicable requirements of the IBC. Supporting steel members must be designed in accordance with the applicable codes, considering local effects on steel elements due to the welded studs.

4.1.2 Combined Loading: For proprietary welded studs subjected to both tension and shear loading, compliance with the following interaction equation must be verified:

$$\frac{p}{P_a} + \frac{v}{V_a} \leq 1.0$$

where:

p = Actual applied tension load on the stud, lbf (N).

P_a = Allowable tension load for the stud, lbf (N).

v = Actual applied shear load on the stud, lbf (N).

V_a = Allowable shear load for the stud, lbf (N)

4.2 Installation:

4.2.1 General: The studs must be installed in accordance with this report, the Hilti Instructions for Use (IFU) and the Hilti F-BT Visual Examination Catalogue (VEC). A copy of these documents must be available on the jobsite at all times during installation. Production welding control and inspection must be conducted in accordance with Sections 9.6 and 9.7 of AWS D1.6, respectively, prior to F-BT stud installation.

4.2.2 Surface Preparation: The surface of the supporting steel must be prepared in accordance with the Hilti IFU and VEC, to ensure that no coating material, rust or other contaminants are present at the weld area and to create an indentation to receive the stud centering tip. See Figure 4 for a sample image of a coated surface after preparation.

4.2.3 Placement: The studs may be welded in any orientation. Studs must be spaced a minimum of $1\frac{3}{8}$ inches (35 mm) on center from one another and a minimum of $1\frac{1}{2}$ inches (38 mm) from the edge of the supporting steel. These distances apply to the threaded stud installation. Greater spacing and edge distance may be needed due to requirements for the attached material.

4.2.4 Welding Process: The temperature of the supporting steel at the time of stud installation must be higher than 32°F (0°C). The applicable H-code must be entered into the Hilti Cordless Stud Fusion Unit. The required size of stud holder must be inserted into the stud fusion hand tool, and the stud must be inserted into the stud holder. The stud centering tip must be placed in the indentation in the prepared location of the supporting steel. If stud positioning and grounding conditions are met, two green indicator lights will be apparent on the stud fusion hand tool. Welding is activated by the use of a trigger on the stud fusion hand tool. When the green lights disappear the welding process is complete, and the hand tool may be removed. If a red indicator light appears, an error has occurred; evaluation of remedial procedures addressed in the IFU and VEC are outside the scope of this report.

4.2.5 Installation of Attached Material: The exposed surface of the carbon steel support must be protected against corrosion. For F-BT-MR SN studs, the sealing washer must be placed over the stud using Hilti setting tool X-WST F3-BT and the applicable adapter for the thread size. Then, the connected material or component is installed over the stud. A washer and nut must be installed in accordance with the construction documents. The nut must be tightened to a torque specified in Table 2A or 2B, as applicable.

5.0 CONDITIONS OF USE:

The F-BT Studs described in this report comply with, or are suitable alternatives to what is specified in, those codes listed in Section 1.0 of this report, subject to the following conditions:

- 5.1 The F-BT studs must be installed in accordance with this report, Hilti's IFU and VEC documents, and the WPS qualified at the jobsite. In the case of a conflict amongst these documents, the most restrictive requirements govern.
- 5.2 Design loads for the F-BT studs must not exceed the available strengths given in Section 4.1.
- 5.3 The F-BT studs must not be used to support loads that are predominantly vibratory, such as those for operation of heavy machinery, reciprocating motors and moving loads.
- 5.4 Construction documents and calculations demonstrating that the design loads do not exceed the available strengths must be submitted to the code official. The calculations must be prepared by a registered design professional when required by statutes of the jurisdiction in which the project is to be constructed.
- 5.5 The F-BT welded stud assemblies are manufactured under a quality control program with inspections by ICC-ES.

6.0 EVIDENCE SUBMITTED

Data in accordance with the [ICC-ES Acceptance Criteria for Proprietary Welded Threaded Studs \(AC540\)](#), dated October 2022.

7.0 IDENTIFICATION

- 7.1 The ICC-ES mark of conformity, electronic labeling, or the evaluation report number (ICC-ES ESR-4647) along with the name, registered trademark, or registered logo of the report holder must be included in the product label.
- 7.2 In addition, packages of studs are identified with the stud designation, as specified in Tables 1A and 1B, and the lot number. The end of the fastener thread of each stud is embossed with the applicable H-code for the Hilti Cordless Stud Fusion unit, as shown in Figure 3.
- 7.3 The report holder's contact information is the following:

HILTI, INC.
7250 DALLAS PARKWAY SUITE #1000
PLANO, TEXAS 75024
(800) 879-8000
HNATechnicalServices@hilti.com
www.hilti.com

TABLE 1A—F-BT-MR SN STUD PRODUCT INFORMATION

STUD DESIGNATION	THREAD LENGTH, L	OVERALL LENGTH, L_1	THREAD SIZE, d_1	WELD BASE DIA., d_2	NECK DIA., d_n
F-BT-MR M6x25 SN (4)	25 mm	34 mm	M6	5 mm	4 mm
F-BT-MR M8x25 SN (4)	25 mm	34 mm	M8	5 mm	4 mm
F-BT-MR M6x25 SN (6)	25 mm	34 mm	M6	5 mm	4.4 mm
F-BT-MR M10x25 SN (10)	25 mm	34 mm	M10	7.2 mm	6.8 mm
F-BT-MR M10x50 SN (10)	50 mm	59 mm	M10	7.2 mm	6.8 mm
F-BT-MR M12x25 SN (10)	25 mm	34 mm	M12	7.2 mm	6.8 mm
F-BT-MR M12x50 SN (10)	50 mm	59 mm	M12	7.2 mm	6.8 mm
F-BT-MR 3/8x1 SN (5/32)	1 inch	1.34 inches	UNC 3/8 inch	5 mm	4 mm
F-BT-MR 3/8x1 SN (3/8)	1 inch	1.34 inches	UNC 3/8 inch	7.2 mm	6.8 mm
F-BT-MR 3/8x1-1/2 SN (3/8)	1 1/2 inches	1.85 inches	UNC 3/8 inch	7.2 mm	6.8 mm
F-BT-MR 3/8x2 SN (3/8)	2 inch	2.36 inches	UNC 3/8 inch	7.2 mm	6.8 mm
F-BT-MR 3/8x4 SN (3/8)	4 inch	4.25 inches	UNC 3/8 inch	7.2 mm	6.8 mm

For SI/Imperial conversions: 1 inch = 25.4 mm.

TABLE 1B—F-BT-MR STUD PRODUCT INFORMATION

STUD DESIGNATION	THREAD LENGTH, L	OVERALL LENGTH, L_1	THREAD SIZE, d_1	WELD BASE DIA., d_2	NECK DIA., d_n
F-BT-MR M6x25 (6)	25 mm	31 mm	M6	5 mm	4.4 mm
F-BT-MR M10x25 (10)	25 mm	31 mm	M10	7.2 mm	6.8 mm
F-BT-MR M10x50 (10)	50 mm	56 mm	M10	7.2 mm	6.8 mm
F-BT-MR M12x25 (10)	25 mm	31 mm	M12	7.2 mm	6.8 mm
F-BT-MR M12x50 (10)	50 mm	56 mm	M12	7.2 mm	6.8 mm
F-BT-MR 3/8x1 (3/8)	1 inch	1.22 inches	UNC 3/8 inch	7.2 mm	6.8 mm
F-BT-MR 3/8x1-1/2 (3/8)	1 1/2 inches	1.73 inches	UNC 3/8 inch	7.2 mm	6.8 mm
F-BT-MR 3/8x2 (3/8)	2 inch	2.20 inches	UNC 3/8 inch	7.2 mm	6.8 mm
F-BT-MR 3/8x4 (3/8)	4 inch	4.09 inches	UNC 3/8 inch	7.2 mm	6.8 mm
F-BT-MR 1/2x1-1/2 (3/8)	1 1/2 inches	1.73 inches	UNC 1/2 inch	7.2 mm	6.8 mm
F-BT-MR 1/2x2 (3/8)	2 inches	2.20 inches	UNC 1/2 inch	7.2 mm	6.8 mm

For SI/Imperial conversions: 1 inch = 25.4 mm.

TABLE 2A—DESIGN INFORMATION FOR F-BT-MR SN STUDS^{1,2}

STUD DESIGNATION	ALLOWABLE STRENGTH (ASD) (lbf)		DESIGN STRENGTH (LRFD) (lbf)		INSTALLATION PARAMETERS			
	Tension	Shear	Tension	Shear	Min. Base Steel Thickness [in. (mm)]	Weld Code	Installation Torque [lbf-ft (Nm)]	Maximum Thickness of Fastened Material [in. (mm)]
F-BT-MR M6x25 SN (4)	405	225	605	335	3/16 (4.75)	H1	4.4 (6)	3/8 (10)
F-BT-MR M8x25 SN (4)								
F-BT-MR M6x25 SN (6)	700	315	1,050	470	1/4 (6)	H2	5.9 (8)	3/8 (10)
F-BT-MR M10x25 SN (10)	1,800	810	2,700	1,215	3/8 (10)	H10	22.1 (30)	3/8 (10)
F-BT-MR M10x50 SN (10)								3/4 (20)
F-BT-MR M12x25 SN (10)								3/8 (10)
F-BT-MR M12x50 SN (10)								3/4 (20)
F-BT-MR 3/8x1 SN (5/32)	405	225	605	335	3/16 (4.75)	H1	4.4 (6)	3/8 (10)
F-BT-MR 3/8x1 SN (3/8)	1,800	810	2,700	1,215	3/8 (10)	H10	22.1 (30)	3/8 (10)
F-BT-MR 3/8x1-1/2 SN (3/8)								3/4 (20)
F-BT-MR 3/8x2 SN (3/8)								3/4 (20)
F-BT-MR 3/8x4 SN (3/8)								3/4 (20)

For **SI/Imperial** Conversions: 1 inch = 25.4 mm, 1 lbf = 4.45 N, 1 lbf-ft = 1.36 Nm.

¹F-BT-MR SN shall only be used with the provided flange locknut.

²Tabulated values apply to supporting steel with a minimum yield strength (F_y) of 36 ksi and a minimum tensile strength (F_u) of 58 ksi.

TABLE 2B—DESIGN INFORMATION FOR F-BT-MR STUDS¹

STUD DESIGNATION	ALLOWABLE STRENGTH (ASD), (lbf)		DESIGN STRENGTH (LRFD) (lbf)		INSTALLATION PARAMETERS				
	Tension	Shear	Tension	Shear	Min. Base Steel Thickness [in. (mm)]	Weld Code	Installation Torque [lbf-ft (Nm)]		Maximum Thickness of Fastened Material [in. (mm)]
							With flange locknut	With standard HDG nut	
F-BT-MR M6x25 (6)	700	405	1,050	605	1/4 (6)	H2	5.9 (8)	5.9 (8)	3/8 (10)
F-BT-MR M10x25 (10)	1,800	1,010	2,700	1,515	3/8 (10)	H10	22.1 (30)	20 (27)	3/8 (10)
F-BT-MR M10x50 (10)									3/4 (20)
F-BT-MR M12x25 (10)									3/8 (10)
F-BT-MR M12x50 (10)									3/4 (20)
F-BT-MR 3/8x1 (3/8)	1,800	1,010	2,700	1,515	3/8 (10)	H10	22.1 (30)	20 (27)	3/8 (10)
F-BT-MR 3/8x1-1/2 (3/8)									3/4 (20)
F-BT-MR 3/8x2 (3/8)									3/4 (20)
F-BT-MR 3/8x4 (3/8)									3/4 (20)
F-BT-MR 1/2x1-1/2 (3/8)									3/4 (20)
F-BT-MR 1/2x2 (3/8)									3/4 (20)

For **SI/Imperial** Conversions: 1 inch = 25.4 mm, 1 lbf = 4.45 N, 1 lbf-ft = 1.36 Nm.

¹Tabulated values apply to supporting steel with a minimum yield strength (F_y) of 36 ksi and a minimum tensile strength (F_u) of 58 ksi.

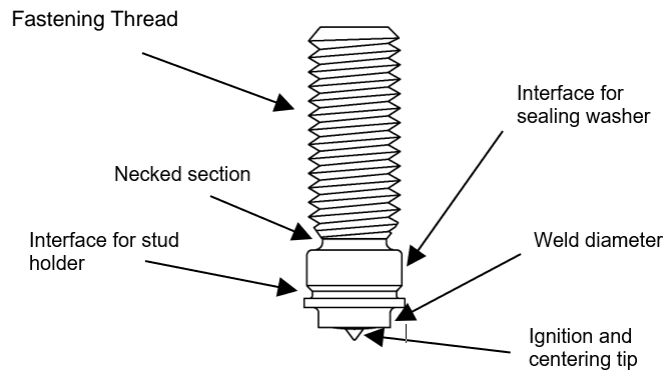

FIGURE 1—F-BT STUD TERMINOLOGY

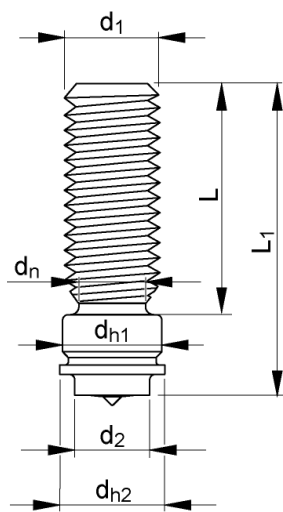

FIGURE 2A—F-BT-MR SN STUD

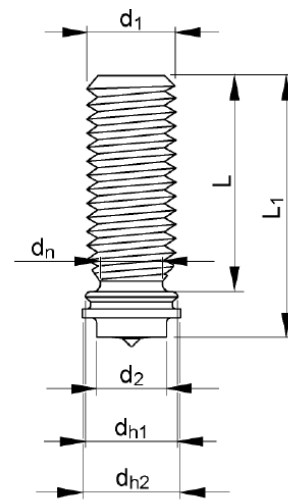

FIGURE 2B—F-BT-MR STUD



FIGURE 3—SAMPLE WELD CODE MARKING



FIGURE 4—SURFACE PREPARATION

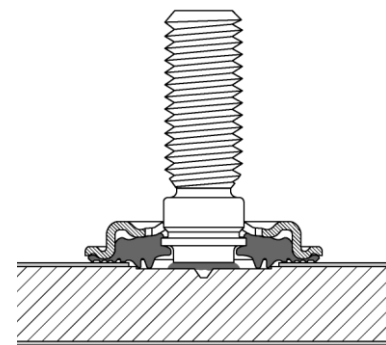

FIGURE 5—F-BT-MR SN STUD INSTALLED WITH SEALING WASHER

	<p>Surface tool FX 3-ST d14, for preparing surfaces with:</p> <ul style="list-style-type: none"> • Bare (uncoated) steel with mill scale • Weldable primer with max. coating thickness: 25 µm
	<p>Surface tool FX 3-ST d20 for preparing surfaces with:</p> <ul style="list-style-type: none"> • Non-weldable primer • HDG coatings • Multi-layer coatings • Maximum coating thickness: 1000 µm
	<p>Cordless stud fusion unit FX 3-A</p> <ul style="list-style-type: none"> • Battery powered • Electrical and mechanical process parameters are pre-set based on selected H-Code • Provides inbuilt process control and provides installation feedback to customers
	<p>Stud fusion hand tool FX 3-HT</p> <ul style="list-style-type: none"> • Can accommodate all F-BT stud sizes • Stud holder component is changed to adjust stud diameter • Accommodates all F-BT stud lengths without need for adjustment • Provides visual feedback and indicators to user
	<p>Gas can FX 3-GC</p> <ul style="list-style-type: none"> • Shielding gas: ISO 14175 – M21 – ArC -18 <ul style="list-style-type: none"> ○ 82% Ar (CAS 7440-37-1) ○ 18% CO₂ (CAS 124-38-9)
	<p>Charger C 53</p> <ul style="list-style-type: none"> • For charging the FX-3-A unit • Quick charge button available
<p align="center">FIGURE 6—HILTI CORDLESS STUD FUSION SYSTEM TOOLS AND EQUIPMENT</p>	

DIVISION: 05 00 00—METALS**Section: 05 05 23—Metal Fastenings****REPORT HOLDER:**

HILTI, INC.

EVALUATION SUBJECT:**F-BT STUDS INSTALLED WITH THE CORDLESS STUD FUSION SYSTEM****1.0 REPORT PURPOSE AND SCOPE****Purpose:**

The purpose of this evaluation report supplement is to indicate that F-BT Studs Installed with the Cordless Stud Fusion System (F-BT Studs), described in ICC-ES evaluation report [ESR-4647](#), have also been evaluated for compliance with the codes noted below as adopted by the Los Angeles Department of Building and Safety (LADBS).

Applicable code editions:

- 2023 *City of Los Angeles Building Code* (LABC)
- 2023 *City of Los Angeles Residential Code* (LARC)

2.0 CONCLUSIONS

The F-BT Studs, described in Sections 2.0 through 7.0 of the evaluation report [ESR-4647](#), comply with LABC Chapter 22, and the LARC, and are subject to the conditions of use described in this supplement.

3.0 CONDITIONS OF USE

The F-BT Studs described in this evaluation report supplement must comply with all of the following conditions:

- All applicable sections in the evaluation report [ESR-4647](#).
- The design, installation, conditions of use and identification of the F-BT Studs are in accordance with the 2021 *International Building Code*® (IBC) provisions noted in the evaluation report [ESR-4647](#).
- The design, installation and inspection are in accordance with additional requirements of LABC Chapters 16 and 17, as applicable.
- Under the LARC, an engineered design in accordance with LARC Section R301.1.3 must be submitted.

This supplement expires concurrently with the evaluation report issued June 2023.

DIVISION: 05 00 00—METALS

Section: 05 05 23—Metal Fastenings

REPORT HOLDER:

HILTI, INC.

EVALUATION SUBJECT:

F-BT STUDS INSTALLED WITH THE CORDLESS STUD FUSION SYSTEM

1.0 REPORT PURPOSE AND SCOPE

Purpose:

The purpose of this evaluation report supplement is to indicate that F-BT Studs Installed with the Cordless Stud Fusion System (F-BT Studs), addressed in ICC-ES evaluation report ESR-4647, have also been evaluated for compliance with the codes noted below.

Applicable code editions:

- 2023 Florida Building Code—Building
- 2023 Florida Building Code—Residential

2.0 CONCLUSIONS

The F-BT Studs, described in ICC-ES evaluation report ESR-4647, comply with the *Florida Building Code—Building* or the *Florida Building Code—Residential*. The design requirements must be determined in accordance with the *Florida Building Code—Building* or the *Florida Building Code—Residential*, as applicable. The installation requirements noted in ICC-ES evaluation report ESR-4647 for the 2021 *International Building Code*® meet the requirements of the *Florida Building Code—Building* and the *Florida Building Code—Residential*, as applicable.

Use of the F-BT Studs for compliance with the High-Velocity Hurricane Zone provisions of the *Florida Building Code—Building* or the *Florida Building Code—Residential* has not been evaluated, and is outside the scope of this supplemental report.

For products falling under Florida Rule 61G20-3, verification that the report holder's quality assurance program is audited by a quality assurance entity approved by the Florida Building Commission for the type of inspections being conducted is the responsibility of an approved validation entity (or the code official when the report holder does not possess an approval by the Commission).

This supplement expires concurrently with the evaluation report, issued June 2023.



Welding Procedure Specification (WPS)

No. CSF-WPS F-BT-MR (HNA)

Version: 02 / 05-25-23

Stud manufacturer	Hilti, Inc.
Stud types	F-BT-MR SN with sealing washer F-BT-MR without sealing washer
Standard	ICC-ES AC540

Examining body	ICC Evaluation Service
Qualification	ICC-ES Evaluation Report ESR-4647

Stud Type	With Sealing Washer	Without Sealing Washer
Imperial	F-BT-MR 3/8x1 SN (5/32)	F-BT-MR 3/8x1 (3/8)
	F-BT-MR 3/8x1 SN (3/8)	F-BT-MR 3/8x1-1/2 (3/8)
	F-BT-MR 3/8x1-1/2 SN (3/8)	F-BT-MR 3/8x2 (3/8)
	F-BT-MR 3/8x2 SN (3/8)	F-BT-MR 3/8x4 (3/8)
	F-BT-MR 3/8x4 SN (3/8)	F-BT-MR 1/2x1-1/2 (3/8)
		F-BT-MR 1/2x2 (3/8)
Metric	F-BT-MR M6x25 SN (4)	F-BT-MR M6x25 (6)
	F-BT-MR M6x25 SN (6)	F-BT-MR M10x25 (10)
	F-BT-MR M8x25 SN (4)	F-BT-MR M10x50 (10)
	F-BT-MR M10x25 SN (10)	F-BT-MR M12x25 (10)
	F-BT-MR M10x50 SN (10)	F-BT-MR M12x50 (10)
	F-BT-MR M12x25 SN (10)	
	F-BT-MR M12x50 SN (10)	

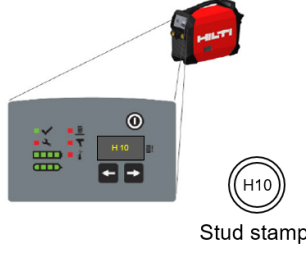
Stud welding process	
	<p>Drawn-arc welding with shielding gas Welding current, welding time, lift and protrusion are automatically adjusted by selecting the weld code H1, H2, and H10. The weld code is stamped on the head of every stud and is given in the instructions for use of the stud.</p> <p>Gas can FX 3-GC, Shielding gas (SG) according to ISO 14175: M21-ArC-18 Gas flow rate: 3 L/min Preheat base material: > 32°F (0°C)</p>
Welding positions	1S, 2S, 4S
Ground positioning	Minimum distance to stud welding position $s_{min} = 4$ in. (100 mm) For 2S: Clamp must be positioning below stud welding position

Stud welding equipment	
Cordless stud fusion unit	FX 3-A
Cordless stud fusion hand tool	FX 3-HT
Stud holder	X-SH F3 M6-1/4", X-SH F3 M8-5/16", X-SH F3 M10-3/8", X-SH F3 M12-1/2"

Stud material	
ASTM designation	S31635, Type 316Ti per ASTM A240/A240-07 or ASTM A276-10
EN steel designation	X6CrNiMoTi17-12-2, Number 1.4571 per EN 10088-3:2014

Base material	
Specification	ASTM A36 (AWS B2.1 M-Number 1 Group 1, ISO 15608 Group 1.1) and ASTM A572 Gr 50 (AWS B2.1 M-Number 1 Group 1, ISO 15608 Group 1.2) CEV ≤ 0.45 %
Minimum thickness	Dependent on stud, see allocation table at the end of this WPS
Maximum thickness	1 3/16 in (30 mm)
Shape	Flat steel

Stud positioning in base material	
Edge distance	$C_{min} = 1 \frac{1}{2}$ in (38 mm)
Spacing between fasteners	$S_{min} = 1 \frac{3}{8}$ in (35 mm)

Stud welding examination	
Observation of	Hilti F-BT Visual Examination Catalogue

Stud welding parameters					
Weld Code	Welding current [A]	Welding time [ms]	Protrusion [mm]	Lift [mm]	Remarks
H10	250 - 280	390 - 440	4.40 - 4.80	2.30 - 2.80	with magnet field
H2	250 - 280	150 - 180	4.20 - 4.60	2.30 - 2.80	with magnet field
H1	250 - 280	80 - 110	4.20 - 4.60	2.30 - 2.80	with magnet field

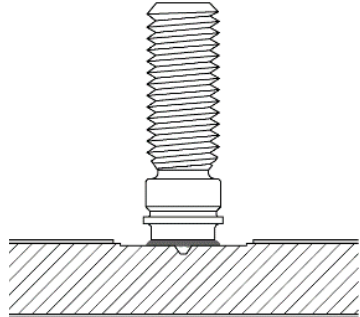
Parent material surface preparation for F-BT-MR-SN studs with sealing washer		
Surface condition	Uncoated	Coated Non-weldable primer HDG coating Duplex coating Multi-layer coating
Visualization	F-BT-MR-SN studs not applicable on uncoated steel.	
Maximum coating thickness	/	1000 µm
Surface tool	/	FX 3-ST d20
Surface preparation method	Surface preparation with appropriate tool. Prepared surface shall be free of any visible dirt, rust and coating. Surface to be welded shall be maintained dry and free from condensation. Maximum time permitted between preparation and welding: 2 hours Consideration of: F-BT Visual Examination Catalogue	

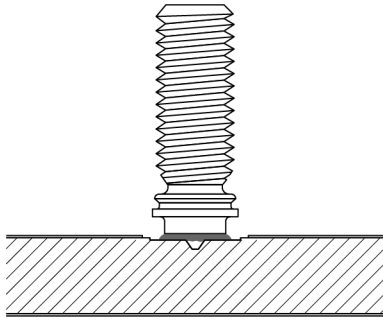
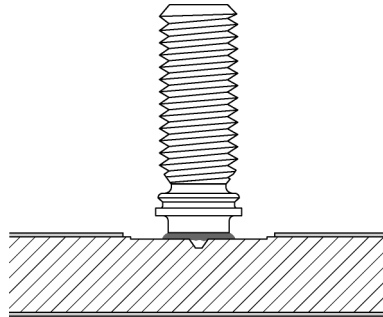
Parent material surface preparation for F-BT-MR studs without sealing washer		
Surface condition	Uncoated or Weldable primer	Coated Weldable and non-weldable primer HDG coating Duplex coating Multi-layer coating
Visualization		
Maximum coating thickness	25 µm	1000 µm
Surface tool	FX 3-ST d14	FX 3-ST d20
Workmanship	Surface preparation with appropriate tool. Surface shall be free of any visible dirt, rust and coating. Surface to be welded shall be maintained dry and free from condensation. Maximum time permitted between preparation and welding: 2 hours Consideration of: F-BT Visual Examination Catalogue	

F-BT-MR-SN studs with sealing washer for welding on coated parent material							
Allocation of Stud – Stud holder – Weld Code							
Surface tool: FX 3-ST d20							
Stud designation	Weld diameter d_2 [mm]	Neck diameter d_n [mm]	Stud holder	Weld Code	Minimum parent material thickness	Stud geometry	
Imperial							
F-BT-MR 3/8x1 SN (5/32)	5	4	X-SH F3 M10-3/8"	H1	3/16" (4.75 mm)		
F-BT-MR 3/8x1 SN (3/8)	7.2	6.8	X-SH F3 M10-3/8"	H10	3/8" (10 mm)		
F-BT-MR 3/8x1 1/2 SN (3/8)	7.2	6.8	X-SH F3 M10-3/8"	H10	3/8" (10 mm)		
F-BT-MR 3/8x2 SN (3/8)	7.2	6.8	X-SH F3 M10-3/8"	H10	3/8" (10 mm)		
F-BT-MR 3/8x4 SN (3/8)	7.2	6.8	X-SH F3 M10-3/8"	H10	3/8" (10 mm)		
Metric							
F-BT-MR M6x25 SN (4)	5	4	X-SH F3 M6-1/4"	H1	4.75 mm (3/16")		
F-BT-MR M8x25 SN (4)	5	4	X-SH F3 M8-5/16"	H1	4.75 mm (3/16")		
F-BT-MR M6x25 SN (6)	5	4.4	X-SH F3 M6-1/4"	H2	6 mm (1/4")		
F-BT-MR M10x25 SN (10)	7.2	6.8	X-SH F3 M10-3/8"	H10	10 mm (3/8")		
F-BT-MR M10x50 SN (10)	7.2	6.8	X-SH F3 M10-3/8"	H10	10 mm (3/8")		
F-BT-MR M12x25 SN (10)	7.2	6.8	X-SH F3 M12-1/2"	H10	10 mm (3/8")		
F-BT-MR M12x50 SN (10)	7.2	6.8	X-SH F3 M12-1/2"	H10	10 mm (3/8")		

F-BT-MR studs without sealing washer for welding on uncoated or coated parent material							
Allocation table Stud – Stud holder – Weld Code							
Surface tool: FX 3-ST d14 for uncoated steel or steel with weldable primer FX 3-ST d20 for coated steel							
Stud designation	Weld diameter d_2 [mm]	Neck diameter d_n [mm]	Stud holder	Weld Code	Minimum parent material thickness of coated steel	Stud geometry	
Imperial							
F-BT-MR 3/8x1 (3/8)	7.2	6.8	X-SH F3 M10-3/8"	H10	3/8" (10 mm)		
F-BT-MR 3/8x1 1/2 (3/8)	7.2	6.8	X-SH F3 M10-3/8"	H10	3/8" (10 mm)		
F-BT-MR 3/8x2 (3/8)	7.2	6.8	X-SH F3 M10-3/8"	H10	3/8" (10 mm)		
F-BT-MR 3/8x4 (3/8)	7.2	6.8	X-SH F3 M10-3/8"	H10	3/8" (10 mm)		
F-BT-MR 1/2x1 1/2 (3/8)	7.2	6.8	X-SH F3 M12-1/2"	H10	3/8" (10 mm)		
F-BT-MR 1/2x2 (3/8)	7.2	6.8	X-SH F3 M12-1/2"	H10	3/8" (10 mm)		
Metric							
F-BT-MR M6x25 (6)	5	4.4	X-SH F3 M6-1/4"	H2	6 mm (1/4")		
F-BT-MR M10x25 (10)	7.2	6.8	X-SH F3 M10-3/8"	H10	10 mm (3/8")		
F-BT-MR M10x50 (10)	7.2	6.8	X-SH F3 M10-3/8"	H10	10 mm (3/8")		
F-BT-MR M12x25 (10)	7.2	6.8	X-SH F3 M12-1/2"	H10	10 mm (3/8")		
F-BT-MR M12x50 (10)	7.2	6.8	X-SH F3 M12-1/2"	H10	10 mm (3/8")		

Hilti Cordless Stud Fusion Record Template

Please choose from one record type from the options below:

- STUD WELDING PROCEDURE SPECIFICATION (WPS)**
PROCEDURE QUALIFICATION RECORD (PQR)
WELDER PERFORMANCE QUALIFICATION RECORD (WQR)
PREPRODUCTION TESTING FORM

Company Name: _____
 Operator Name: _____
 Shift – Date/Time: _____
 Test Number / Record Number: _____
 Supporting PQR Number(s): _____

Stud

Model: Hilti F-BT-MR _____
 Part #: _____
 Stud Material: Stainless Steel 316Ti (EN 10088-2 1.4571)

Base Material

Specification: _____
 Alloy and Temper: _____
 Minimum Thickness: _____
 Shape: _____

Surface Conditions

Coating: _____
 Coating Thickness: _____

Cleaning method – See Hilti Installation Instructions

Drilling Tool: SF 6H-22 SF 8M-A22
 Surface Tool (bit): FX 3-ST d14 FX 3-ST d20

Minimum Ambient Temperature 32°F

Welding Equipment – Hilti Cordless Stud Fusion System

Cordless Stud Fusion unit FX 3-A
 Hand tool FX 3-HT
 Gas can GC FX 3

Setting Code (H-Code)

H1 H2 H10

Welding Position:

1S - Flat (Down hand) 2S - Horizontal (Side hand) 4S - Overhead

Stud Base Sketch / Application Detail

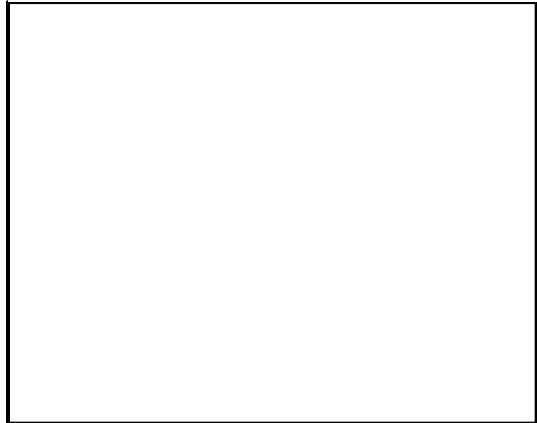

WELD TEST RESULTS

Stud No.	Visual Acceptance	Option #1 Bend Test	Option #2 Tension Test	Option #3 Torque Test
1				
2				
3				
4				
5				
6				
7				
8				
9				
10				

Mechanical tests conducted by: _____ Date: _____
(Company)

We, the undersigned, certify that the statements in this record are correct and that the test welds were prepared, welded, and tested in conformance with the requirements of Clause 9 of AWS D1.6/D1.6M-(_____) *Structural Welding Code—Stainless Steel* or AWS B2.1/B2.1M, (_____), *Specification for Welding Procedure and Performance Qualification*

Signed by: _____ Title: _____ Date: _____
(Contractor/Applicator/Other)

Company: _____